

DRIVE - INSTRUCTION MANUAL

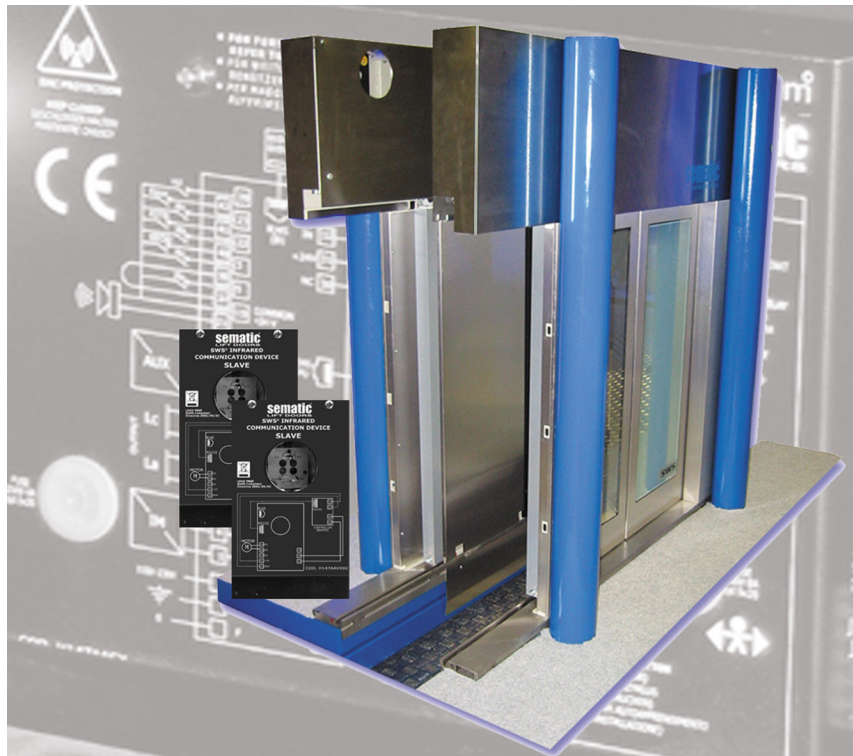

# SWS<sup>®</sup> Drive

Code	<b>PM.2.004563.EN</b>
Edition	<b>E 2016-09-28</b>
Version	<b>V 2017-10-05</b>
SEM ID	<b>809-000-000</b>



**safety in motion**<sup>™</sup>

No part of this publication may be reproduced or translated, even in part, without prior written permission from WITTUR.

Subject to change without notice!

[info@wittur.com](mailto:info@wittur.com)  
[www.wittur.com](http://www.wittur.com)

© Copyright WITTUR 2017



**1 Preface ..... 7**

**2 What is the Sematic Wireless System® SWS (Patented) ..... 8**

2.1 General Features .....8

2.2 Device description .....9

**3 Connections from and to the Main Lift Controller and external devices..... 10**

3.1 Connections from and to the Main Lift Controller and external devices .....12

3.1.1 RS 232..... 12

3.1.2 Wireless System - MASTER and SLAVE ..... 12

**4 Preliminary operations to the controller functioning and of the controller functioning characterization ..... 13**



## Confidentiality agreement Disclaimer

The software/hardware “Sematic Drive System®” and all the relevant information, ideas, concepts and know-how are confidential and the exclusive property of Sematic.

All information relevant to this instruction manual and any other support supplied by Sematic must be kept confidential and proprietary to Sematic and shall not to be copied or reproduced in any form whatsoever.

Any information contained in the “Sematic Drive System®” shall not be disclosed to anyone, without Sematic’s written consent apart from authorized representatives employed by the user which commits itself to the confidentiality clause.

The Company that makes use of the Sematic Drive System®, binds itself not to use confidential informations owned by Sematic and not to compile or reengineer the Sematic Drive System® and any information in it contained.

Sematic regards all the information contained in this instruction manual to be correct at the time of printing. This information does not constitute any obligation to Sematic and can be modified without prior notification. Sematic cannot be held responsible for any possible damages or claims caused to items or persons due to errors or misunderstandings within the contents of this instruction manual.



**We care about your integrated solution!**

**COMPONENT SYSTEMS**

- *Automatic lift doors*
- *Frame and frameless glass doors*
- *Enhanced car door operator solutions*
- *Complete cabins*
- *Car Frames*
- *Custom integrated packages*
- *Special lift doors, cabins and car frames*

**ELEVATOR SYSTEMS & SUBSYSTEMS**

- *Rope traction elevators*
- *Machineroomless roped elevators*
- *Modular hydraulic elevators*
- *Hydraulic elevators*
- *Panoramic elevators*
- *Hospital elevators*
- *Special executions*

# 1 PREFACE

This manual has been drafted taking into account that the Company installing genuine Sematic products will comply with the following necessary requirements:

- *personnel responsible for the installation and/or maintenance of the doors must be familiar with the General and Specific regulations in force on the subjects of work safety and hygiene (89/391/CEE - 89/654/CEE - 89/656/CEE);*
- *personnel responsible for the installation and/or maintenance must be familiar with the Sematic product and must have been trained by Sematic or by an authorized Sematic agent;*
- *installation equipment used must be in good working order with all measuring instruments calibrated (89/655/CEE).*

## Sematic:

- *undertakes to update the present manual and send the customer copies of all new updates together with material;*
- *within its continuous product improvement policy, reserves the right to make changes to the designs and materials of its products. Sematic will give an agreed reasonable time to all its customers to allow them to adapt to the new changes their complementary current constructions;*
- *guarantees a good performance only of the original parts sold directly and correctly installed.*

## Therefore:

parts manufactured and/or added to the Sematic product without having it checked by Sematic, or non-original parts based upon a Sematic design (even if supplied by authorised agents) cannot be considered under guarantee since the following conditions have not been ensured:

1. *Quality control of raw material supply*
2. *Process control*
3. *Product control*
4. *Conformity tests according to Sematic specifications*

## Furthermore, Sematic

- *guarantees the performance life of its products only if correctly stored (indoors storage at temperatures ranging between 0°C and +60 °C out of direct sunlight) and correctly installed;*
- *guarantees the perfect performance of the products installed in environments with temperatures between 0°C and +60 °C and with a non-condensing, relative humidity level inbetween 20% and 80%. (Special note: for temperatures and humidity rates outside these ranges, please consult our Technical Dept.)*

The product is compliant with the following EU Directives:

- *98/37/CE Machinery Directive and subsequent modifications (when applicable)*
- *2014/33/EU Lifts Directive*
- *93/68/CEE Markings*
- *90/269/CEE Heavy loads handling*
- *Noise (Acoustic emission) 86/188/CEE modified according to Directive 98/24/CEE*
- *Electromagnetic compatibility 2014/30/EU*
- *Low Voltage Directive 2014/35/EU*

and with the following particular standards:

- *EN81-1/2;*
- *EN81-20/50;*
- *AS1735;*
- *EN12015/EN12016;*
- *GB7588 + XG1;*

The present document has been drafted in accordance with EN13015

Taking into account, during all project planning, the Risk Assessments relating to:

- RISKS OF MECHANICAL HAZARDS**
  - *Squeezing during operations*
  - *Squeezing after Trapping caused by friction (glass panels)*
  - *Cuts caused by sharp edges, or static sharp pieces*
- RISKS OF ELECTRICAL HAZARDS**
  - *Persons in contact with energized parts (direct contact)*
  - *Persons in contact with parts that become energized due to a fault (indirect contact)*
- RISKS OF OVERHEATING**
- RISKS GENERATED BY NOISE**
- RISKS GENERATED BY VIBRATION**
- RISKS GENERATED BY MATERIALS AND SUBSTANCES**

## 2 WHAT IS THE SEMATIC WIRELESS SYSTEM® SWS (PATENTED)

### 2.1 GENERAL FEATURES

Usually the cabin doors and the landing doors of a normal lift or of a sloping lift plant are coupled with a mechanical system which allows the cabin doors to jointly open the landing doors at every storey. This system envisages a motor and a coupling skate for the cabin door, whereas the landing doors are engaged through their own lock.

The Sematic Wireless System® allows the control panel to check both cabin and landing doors when they face each other without any mechanical engagement.

**This system allows communication between cabin and landing doors, even though they operate with independent motorization and mechanics; the system works always in accordance to the Norm EN81, although the control panel signal arrives only to the cabin door, as with the traditional systems.**

**Once the signal arrives, it is the cabin door itself to transmit it to the landing door which simultaneously opens.**

This is possible thanks to two peripheral small scale and weatherproof infra-red receiver-transmitter systems for the data exchange.

Due to security reasons the communication system insulates the motor when the cabin is running and particularly when the cabin is not positioned in front of the landing door within the lock release zone.

As a rule it is advisable to ensure that the control panel sends the opening signal only after the communication between cabin and landing door is restored, that is when the cabin is within the lock release zone.

**The communication system is bidirectional and asymmetrical (type Master->Slave) with the cabin door acting as Master and the landing door acting as Slave.**

Beside the bidirectional and asymmetrical transmission of opening and closing signals, the system envisages also incoming signals from obstacle surveying devices (such as photocells), which will synchronously work on both cabin and landing doors, although they are received only from one of them doors.

The nudging effect when an obstacle is detected is activated on both cabin and landing door and it requires the re-opening of both doors, even though only one of them is involved in the obstacle detection.

The door lock device is installed on both cabin and landing doors: this means that both doors cannot be manually opened without the appropriate key.

**Therefore the Sematic Wireless System is suitable for person and good lifts with a slope included between 15° and 75° in comparison with the horizontal level, for doors with side engagement, the level of which is parallel to the cabin motion direction.**

The Sematic Wireless System is a Sematic patent pending system which prevents the opening of the doors outside the lock release zone. The Sematic locking device complies with the Lift Directive 95/16/CE and the Norm EN-81-1/2:1998.



## 2.2 DEVICE DESCRIPTION



Fig. 1 cod. B157AAEX01-SWS

The system consist:

- of a car door operator (1)
- an Encoder controller electronic card with microprocessor (2),
- a DC motor (3) with optical Encoder feedback
- a Wireless System (4)

The Sematic Drive System® automatically controls the opening and closing of the lift doors, monitoring the timing, current variations, speeds (high, low, acceleration and deceleration curves), various safety systems (reversingsystem, Limited Door Reversal etc.) and faults (high voltage, signal failure, ...).

There are two independent speed curve profiles for the opening and closing cycles which can be modified by means of the door controller push buttons or by means of the Sematic handset (an optional 8 digit keypad and display accessory which can be connected to the card by an RJ45 plug).

The handset (5) is a key pad that allows viewing and modification of the function parameters stored in the controller. It is important to use the Sematic handset for installation or maintenance, as it enables viewing and/or variation of the Encoder parameters, systems, and operation errors.

Furthermore, it is possible to use the Sematic handset directly from the inside of the car (6). Making it possible to monitor and modify the door operating parameters from a completely safe position, and also to control the movement of the coupled car and landing doors during their effective operating cycle.

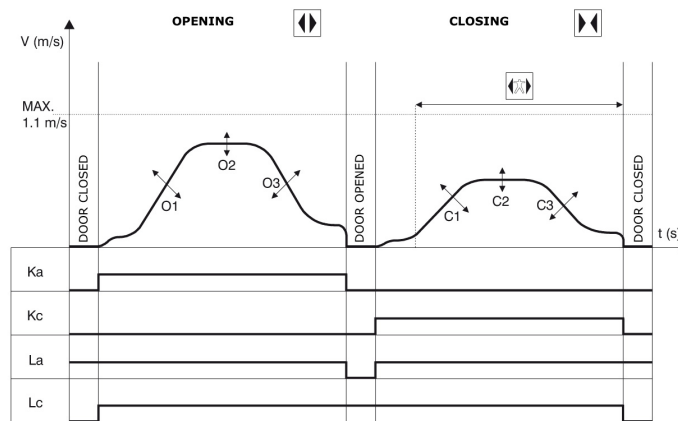

Ka	Door opening
Kc	Door closing
La	Open Limit
Lc	Close limit
	Closing cycle
	Active reversing system
	Opening cycle

### 3 CONNECTIONS FROM AND TO THE MAIN LIFT CONTROLLER AND EXTERNAL DEVICES

#### Car Door

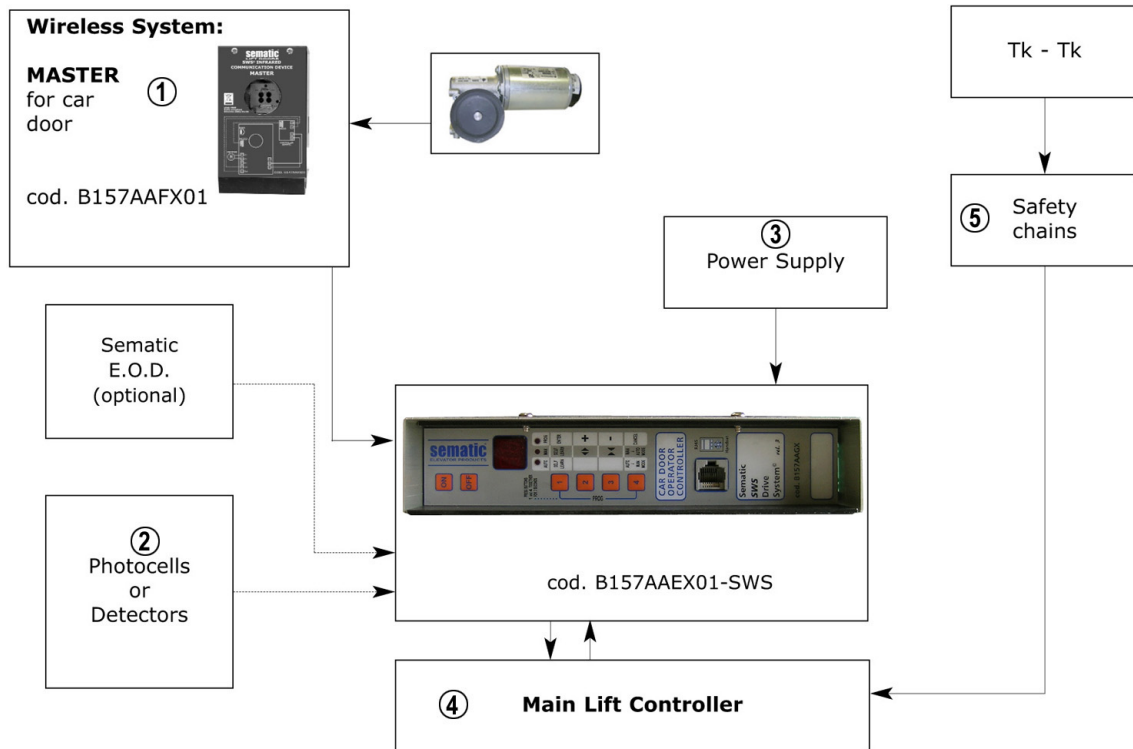

1	MASTER for car door	3	Power supply	5	Safety chains
2	Photocells or Detectors	4	Main Lift Controls		

## Landing Door

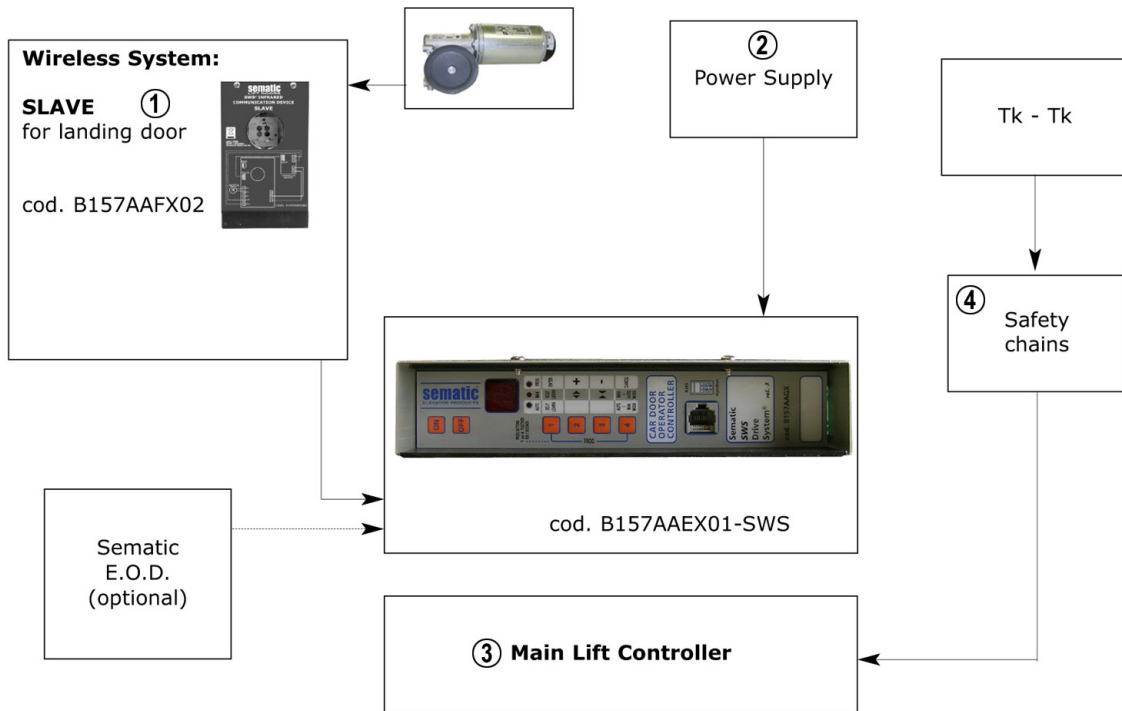

1	SLAVE for landing door	3	Main Lift Controls
2	Power supply	4	Safety chains

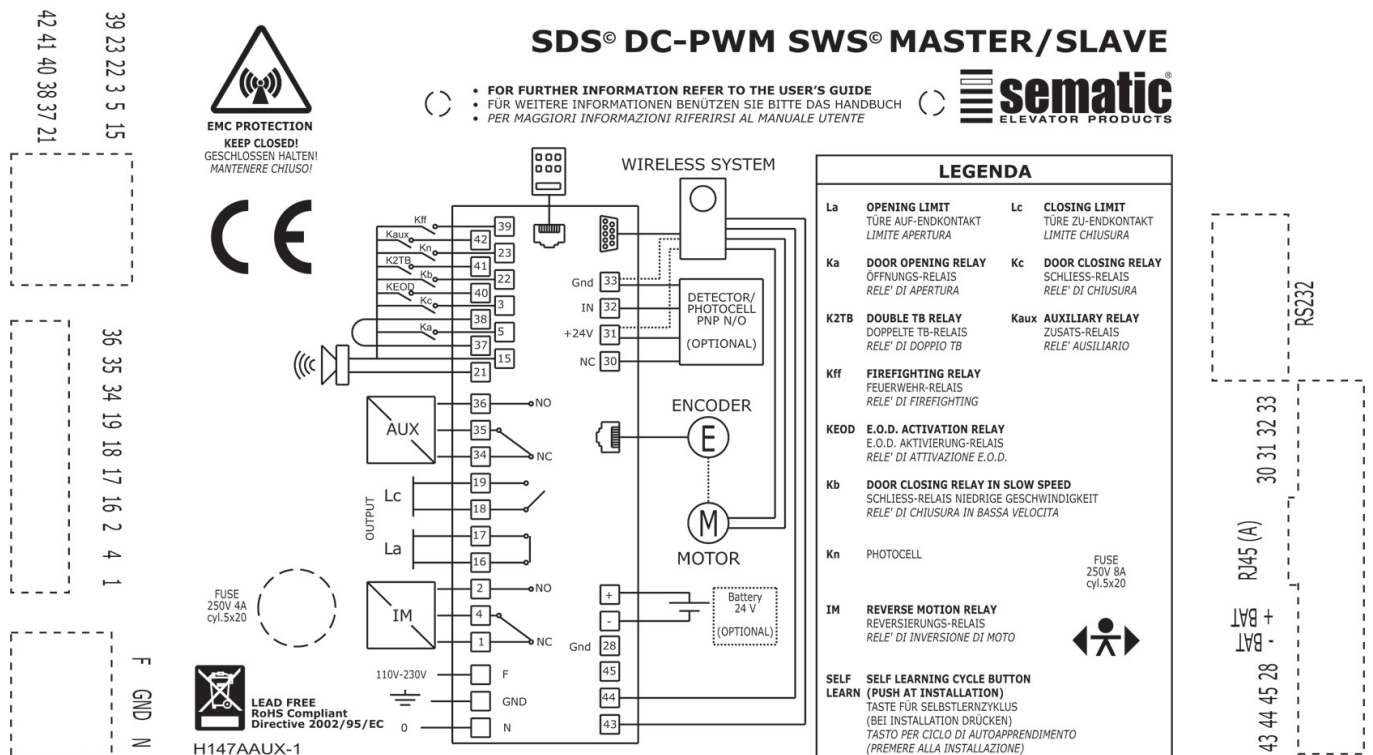

### 3.1 CONNECTIONS FROM AND TO THE MAIN LIFT CONTROLLER AND EXTERNAL DEVICES

The connections to carry out are the same as for the Controller Sematic Drive System® (code 808-000-000) but with the following additions:

#### 3.1.1 RS 232

	<p>It is used for the connection of the door controller and the Wireless System via RS232 (the controller for the SWS System has this additional outlet compared with the standard version of the Sematic Drive System® code B157AAEX01)</p>
---	--

#### 3.1.2 Wireless System - MASTER and SLAVE

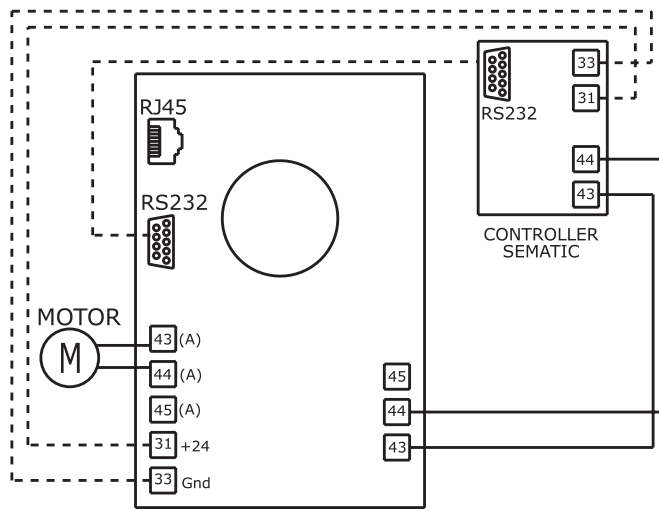

The wireless System allows infra-red communication between the cabin and landing doors. The cabin door is equipped with a Wireless System called "Master" and the landing door with a Wireless System called "Slave"

 The motor is connected to the Wireless System and is powered only if there is communication between Master and Slave (coupling conditions which determines the lock release zone).

This is due to security reasons in order not to allow the door movement outside the lock release zone.

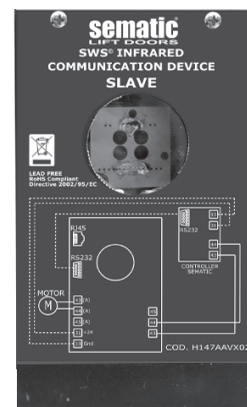
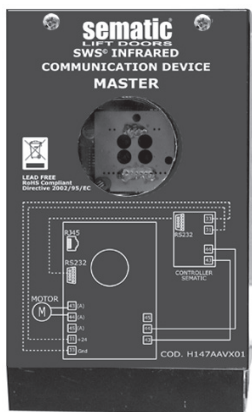

## 4 PRELIMINARY OPERATIONS TO THE CONTROLLER FUNCTIONING AND OF THE CONTROLLER FUNCTIONING CHARACTERIZATION

The operations of regulating and characterizing of the function and communication between motor and controller are possible only when the cabin door is coupled to the landing door and therefore the relevant Wireless Systems® communicate.

The system works with the controller Sematic Drive System 3.0® and the operations allowed are the same as described in the booklet 808-010-000

To check the correct plant functioning verify the following:

- *Communication between the infrared sensors of Master and Slave: the doors work only when they are within the lock release zone (+ or - 110 mm. along the cabin movement direction).*
- *When the doors are beyond the lock release zone and therefore do not communicate with each other, they must not move even though a signal arrives from the main lift controller.*



**Attention:** the above condition is abnormal for the door controller which will signal an error (Motor Jerk Alarm) and then will auto-reset

By connecting the handset it is possible to visualize these signals. As to the visualization and management of the door controller memorized alarms, please refer to the Sematic handbook Sematic Drive System® rel. 4 cod. 808-010-000

- *Alignment between cabin and landing door: these must open and close without any delay between themselves. The speed profiles can be adapted to meet this condition.*
- *The option SERIAL BUS under the menu PROFILE SETTING --> ADVANCED SETTING must be set as follows*



- SWS MASTER for the cabin door (Master)
- SWS SLAVE for the landing door (Slave)

- *The option REVERSING MOTION under the menu GENERAL OPTION must be set as:*



- INTERNAL for the cabin door (Master)
- EXTERNAL for the landing door (Slave)





WITTUR

**YOUR GLOBAL PARTNER FOR COMPONENTS,  
MODULES AND SYSTEMS IN THE ELEVATOR INDUSTRY**

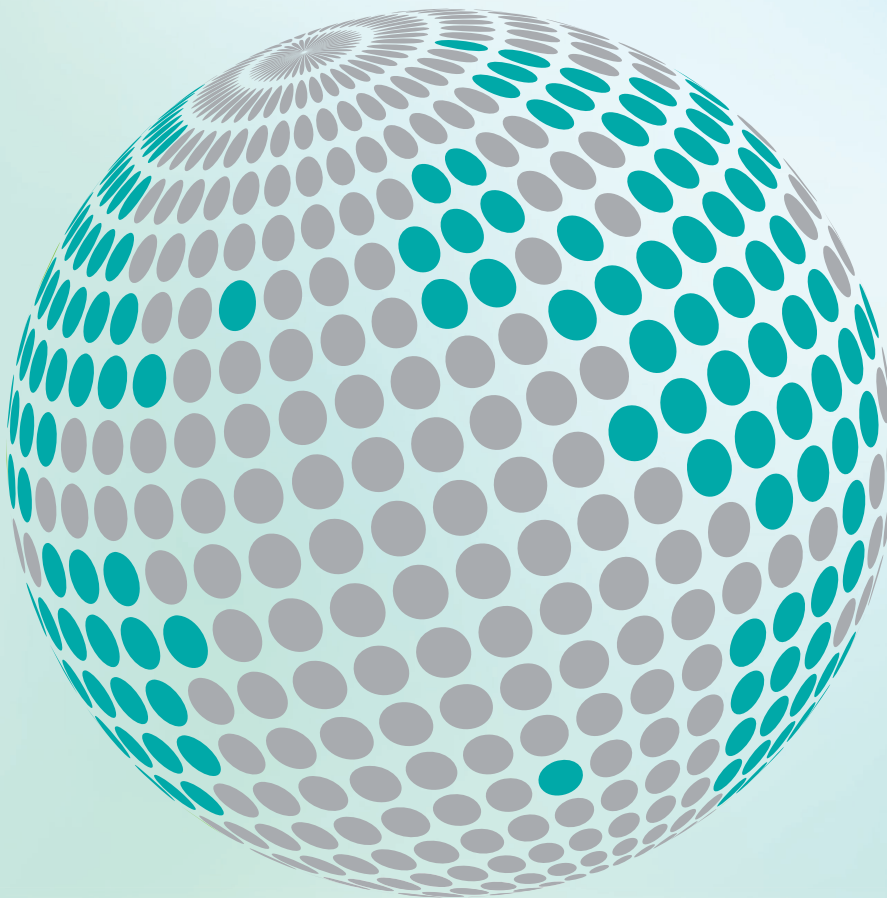

[www.wittur.com](http://www.wittur.com)

More information  
about Wittur Group  
available on-line.



**SELCOM**<sup>®</sup>  
a WITTUR brand

**Liftmaterial**  
a WITTUR brand

**sematic**<sup>®</sup>  
a WITTUR brand